

LIQUI-FLOW®

Series L10 / L20 Digital Mass Flow Meters / Controllers for Liquids

> Introduction

Bronkhorst High-Tech B.V., the European market leader in thermal Mass Flow Meters/Controllers and Electronic Pressure Controllers, has more than 25 years experience in designing and manufacturing precise and reliable measurement and control devices. With a wide range of instruments, Bronkhorst High-Tech offers innovative solutions for many different applications in many different markets. The instruments are made to customers' specification, in various styles, suitable for use in laboratory, industrial environment, hazardous areas, semiconductor processing or analytical equipment.

> LIQUI-FLOW® series L10 / L20

Bronkhorst High-Tech B.V. has been the pioneer in the field of micro to low flow liquid metering instruments based on a thermal measuring principle. The digital LIQUI-FLOW® Mass Flow Meter was designed to cover the range between 5 and 1000 g/h (Full Scale) in a compact instrument with a fast response. The Flow Meter is basically a stainless steel tube without any moving parts or built-in obstructions. The heater/sensor assembly is arranged around the tube and, by following the anemometric principle: a constant difference in temperature (ΔT) is created and the energy required to maintain the ΔT is dependent of the mass flow rate. Due to the benefits of the unique patented sensor, the fluid will be warmed to a maximum of 5°C, thereby making the L10/L20 series suitable for fluids with low boiling points.

> Liquid flow control

Flow control is achieved by integrating a control valve onto the body of the Liquid Flow Meter, or by mounting it as a separate component (in IP65 configuration). This control valve has a purge connection on top of the sleeve that enables easy elimination of air or gas when starting up the system. The electronic control function forms part of the normal circuitry in the liquid flow meter, so the need for an external controller is eliminated. For an alternative way of liquid flow control, i.e. by using a close-coupled pump, please see our leaflet 'Liquid Dosing Systems'.

> Multi-Bus technology

Bronkhorst High-Tech developed their latest digital instruments according to the "multi-bus" principle. The basic pc-board on



the instrument contains all of the general functions needed for measurement and control. It has analog I/O-signals and also an RS232 connection as a standard feature. In addition there is the possibility of integrating an interface board with DeviceNet™, Profibus-DP®, Modbus-RTU or FLOW-BUS protocol.

> General LIQUI-FLOW® features

- ◆ fast and accurate measuring signal
- ◆ insensitive to mounting position
- ◆ very small internal volume
- ◆ suitable for liquids with low boiling points
- ◆ for laboratory and OEM applications
- ◆ also available for industrial applications, with IP65 housing, ATEX Cat. 3, Zone 2

> Digital features

- ◆ DeviceNet™, Profibus-DP®, Modbus-RTU or FLOW-BUS slave
- ◆ RS232 interface
- ◆ alarm and counter functions

> Fields of application

- ◆ Semiconductor industry
- ◆ HPLC applications
- ◆ Chemical industry
- ◆ Food & Pharmaceutical industry
- ◆ Analytical laboratories

> Technical specifications

Measurement / control system

Accuracy, standard (based on actual calibration)	: ±1% FS
Turndown	: L10 Series 1 : 20 (5 ... 100%) L20 Series 1 : 50 (2 ... 100%)
Reproducibility	: ±0,2% FS typical H ₂ O
Settling time (controller)	: < 2 seconds
Operating temperature	: 5...50°C
Temperature sensitivity	: ±0,1% FS/°C
Attitude sensitivity	: negligible
Warm-up time	: 30 min for optimum accuracy; 10 min. for accuracy ±2% FS

Mechanical parts

Material (wetted parts)	: Stainless steel 316L / 320; other on request
Process connections	: 1/8", 1/4" or 6 mm OD compression type; 1/8" or 1/4" face seal male; other on request
Seals	: Kalrez-6375; other on request
Ingress protection (housing)	: IP40 or IP65

Electrical properties

Power supply	: +15...24 Vdc
Power consumption	: Meter: 100 mA; Controller: 350 mA; Add 50 mA for Profibus, if applicable
Analog output/command	: 0...5 (10) Vdc or 0 (4)...20 mA (sourcing output)
Digital communication	: Standard: RS232 Options: Profibus-DP®, DeviceNet™, Modbus-RTU, FLOW-BUS

Electrical connection IP40 configuration

Analog/RS232	: 9-pin D-connector (male);
Profibus-DP®	: bus: 9-pin D-connector (female); power: 9-pin D-connector (male);
DeviceNet™	: 5-pin M12-connector (male);
Modbus-RTU/FLOW-BUS	: RJ45 modular jack

Electrical connection IP65 configuration

Analog/RS232	: 8 DIN (male)
Profibus-DP®	: bus: 5-pin M12 (female); power: 8 DIN (male)
DeviceNet™	: 5-pin M12 (male)
Modbus-RTU/FLOW-BUS	: 5-pin M12 (male)

Calibration

References	: Verified by NKO, the Dutch calibration organisation, and traceable to Dutch and international standards.
Liquids	: Standard calibration: H ₂ O or IPA (Isopropyl Alcohol); for other liquids apply to factory.
System	: Precision laboratory balances.

Technical specifications subject to change without notice.



L23 Mass Flow Meter for Liquids

> Models and flow ranges

Liquid Mass Flow Meters; PN100 (pressure rating 100 bar)

Model	min. flow	max. flow
L13 / L13I	0,25...5 g/h	5...100 g/h
L23 / L23I	2...100 g/h	20...1000 g/h

Liquid Mass Flow Controllers; PN100 (P-max 100 bar)

Model	min. flow	max. flow
L13V02 / L13I+C2I	0,25...5 g/h	5...100 g/h
L23V02 / L23I+C2I	2...100 g/h	20...1000 g/h

Indicated ranges are based on H₂O.

Higher pressure ratings are available on special request.

> Model number identification

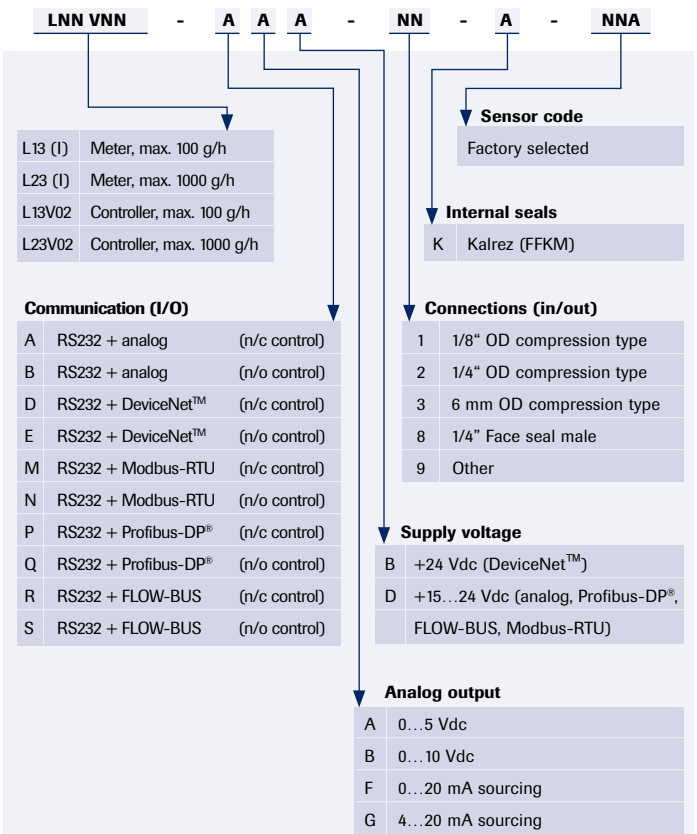

> Dimensions and weights

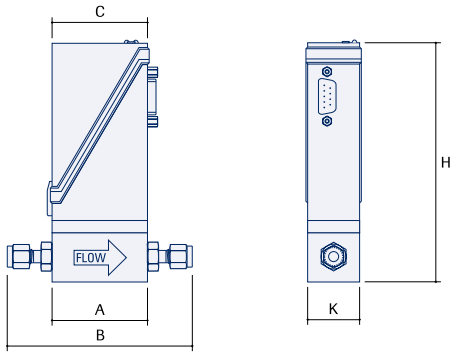

Mass Flow Meter

Model	A	B	C	H	K	Weight (kg)
L13 (1/8")	47	98	47	118	25	0,4
L23 (1/4")	47	102	47	121	25	0,4

Dimensions in mm

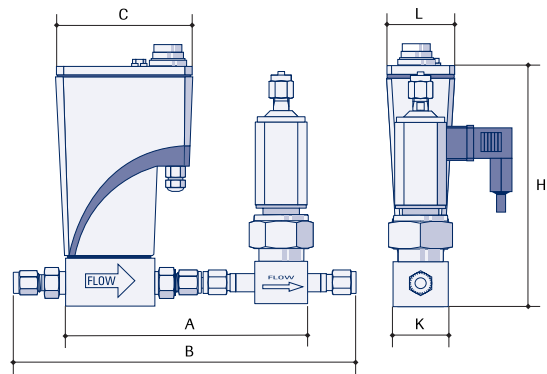

IP65 Mass Flow Controller

Model	A	B	C	H	K	L	Weight (kg)
L13I+C2I (1/8")	127	178	74	125	29	36	1,4
L23I+C2I (1/4")	127	178	74	128	29	36	1,4

Dimensions in mm

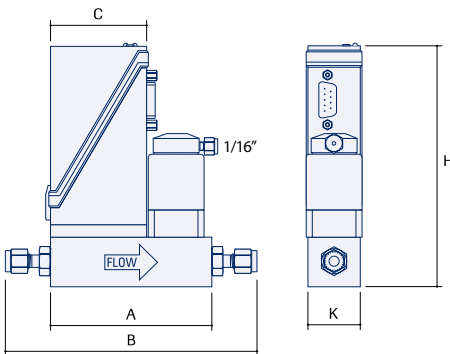

Mass Flow Controller

Model	A	B	C	H	K	Weight (kg)
L13V02 (1/8")	77	128	47	118	25	0,7
L23V02 (1/4")	77	132	47	121	25	0,7

Dimensions in mm

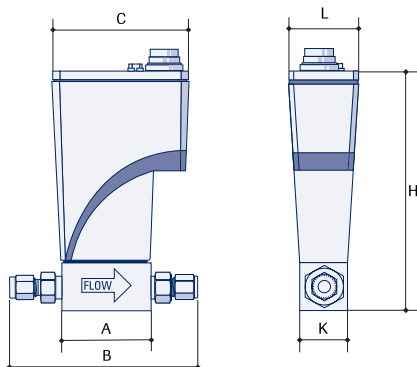

IP65 Mass Flow Meter

Model	A	B	C	H	K	L	Weight (kg)
L13I (1/8")	47	98	74	125	25	36	0,9
L23I (1/4")	47	102	74	128	25	36	0,9

Dimensions in mm

> Industrial style LIQUI-FLOW® series

The LIQUI-FLOW® series L10I/L20I digital Liquid Flow Meters / Controllers for low flow ranges are equipped with a rugged 'industrial style' (IP65) pc-board housing for use in industrial environments or even Zone 2 hazardous areas, due to their ATEX category 3 approval. The instruments operate on a thermal, thru-flow measuring principle. The flow meter can be connected to a control valve to form a closed control loop. The standard direct acting valve (model C2I) is normally closed, has a pressure capability of 100 bar (1500 psi) and a purge connection for easy elimination of air or gas.



L23I Mass Flow Meter, IP65 configuration



IP65 Mass Flow Meter with close-coupled Control Valve

> Application examples

Verifying pumps

LIQUI-FLOW® flow meters are used in analytical applications in combination with HPLC pumps, verifying the pump performance or even, as shown in this example, close-coupled with a gear pump. Using the integrated PID controller, the setpoint signal continuously adjusts the rotation speed of the pump.

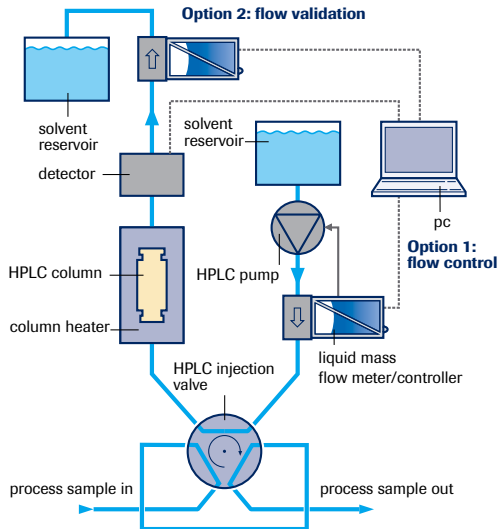

GMP validation in food & pharma filling processes

In food and pharmaceutical applications critical filling processes must be very accurately and, above all traceably documented. LIQUI-FLOW® Series L10/L20 are particularly suitable for this task. The main features of these digital instruments are: high precision, fast response, compact design and a very small internal volume.

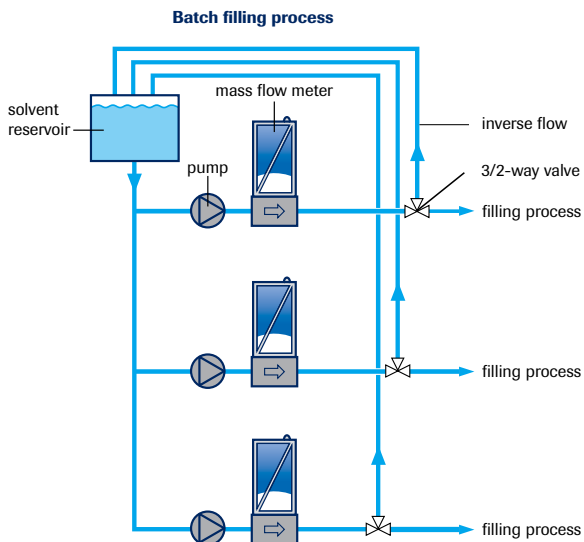

> Vaporizing

Liquid Delivery with Vapour Control

The CEM-System (Controlled Evaporation and Mixing) is an innovative Liquid Delivery System (LDS) that can be applied for atmospheric or vacuum processes. The vapour generation system consists of a liquid flow controller, an MFC for carrier gas and a temperature controlled mixing and evaporation device. The system is suitable for mixing liquid flows of 0,25-1200 g/h resulting in saturated vapour flows of 50 ml_n/min up to 100 l_n/min. This vaporizer system can replace bubblers. New opportunities created with the CEM-system: mixtures can be evaporated and even solids, dissolved in solvents can be vaporised successfully.

Features

- ◆ Accurately controlled gas/liquid mixture (mass flow)
- ◆ Fast response
- ◆ High reproducibility
- ◆ Handles water, solvents, liquid mixtures
- ◆ Very stable vapour flow
- ◆ Flexible selection of gas/liquid ratio
- ◆ Lower working temperature than conventional system

Vapour delivery applications

- ◆ CVD (Chemical Vapour Deposition), e.g. for hardening, thin film coating or planarization processes
- ◆ Testing/calibration of analyzers with reference gas vapor concentrations
- ◆ Toxic gas effects on protective clothing
- ◆ Analyzers with reference H₂O vapour concentrations
- ◆ Humidification of fuels
- ◆ Anaesthetics

